

# Globe Valves

## Type 01252 - Bellow Sealed Globe Valve



### Cryogenic-Bellow Sealed Globe Valve, PN50

Stainless steel body and topwork,  
 "live loaded" gland packing  
 "cleaned and degreased for oxygen service"

#### Part No. 01252.X.002\*

\* Butt weld connection for stainless steel pipes acc. to ISO 1127 or ASTM A312

#### Part No. 01252.X.0024

Socket weld connection for stainless steel pipes acc. to ISO 1127 or ASTM A312

Available options - on request only:

- Welded stainless steel stubs acc. to ISO 1127 or ASTM A312 - length FF + 200mm
- Extension H up to 900mm
- Valve with control disc (tapered design)
- Further pipe wall thicknesses

### Applications:

Approved for air gases, vapours and cryogenic liquefied gases incl. LNG.  
 Working temperature: -196°C / -321°F (77K) up to +120°C / +248°F (393K)  
 Leak rate: 10<sup>-6</sup> mbar ltr / sec outside  
 10<sup>-4</sup> mbar ltr / sec seat



| Materials         | DIN EN                     | ASTM              |
|-------------------|----------------------------|-------------------|
| 1 Body            | 1.4308                     | A 351 CF8         |
| 2 Valve seal      | PTFE / Carbon filled (25%) |                   |
| 3 Disc            | 1.4301                     | A 276 Grade 304   |
| 4 Bonnet gasket   | PTFE                       |                   |
| 5 Headpiece       | 1.4301                     | A 276 Grade 304   |
| 6 Bellow stem     | 1.4571                     | A 276 Grade 316Ti |
| 7 Bolts           | 1.4301/A2                  | A 194 B8          |
| 8 Bellow          | 1.4571                     | A 276 Grade 316Ti |
| 9 Elongation tube | 1.4541                     | A 213 TP 321      |
| 10 Headpiece      | 1.4301                     | A 276 Grade 304   |
| 11 Bush           | CW452K                     | B 159 UNS C51900  |
| 12 Stem           | 1.4301                     | A 276 Grade 304   |
| 13 Gland packing  | Graphite / PTFE            |                   |
| 14 Gland nut      | 1.4305                     | A 276 Grade 303   |
| 15 Handwheel      | Aluminium alloy            |                   |

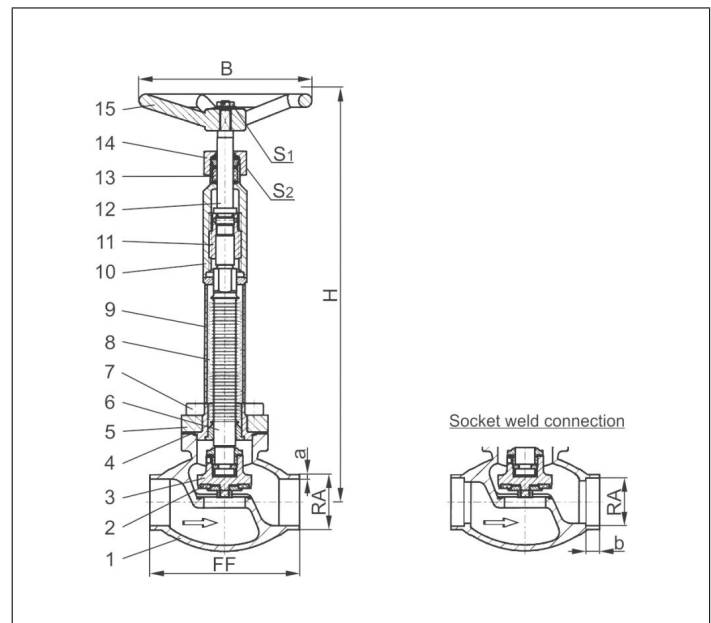

Standard marking acc. to Pressure Equipment Directive 2014/68/EU (PED).



| Type 01252 - Standard design  | Technical data    |                               |       |       |       |       |      |       |       |       |
|-------------------------------|-------------------|-------------------------------|-------|-------|-------|-------|------|-------|-------|-------|
| Nominal size                  | DN                | 10                            | 15    | 15    | 20    | 25    | 32   | 40    | 40    | 50    |
| Dimension code                | .X.               | 1012                          | 1517  | 1521  | 2026  | 2533  | 3238 | 4042  | 4048  | 5060  |
| Face-to-face dimension        | FF                | 70                            | 85    | 85    | 100   | 115   | 115  | 130   | 130   | 155   |
| Height                        | H                 | 380                           | 380   | 380   | 380   | 380   | 380  | 380   | 380   | 380   |
| Outside pipe-Ø ISO 1127       | RA                | 12.0                          | 17.2  | 21.3  | 26.9  | 33.7  | 38.0 | 42.4  | 48.3  | 60.3  |
| Wall thickness pipe ISO 1127  | a                 | 1.0                           | 1.6   | 2.0   | 2.0   | 2.0   | 2.0  | 2.0   | 2.0   | 2.0   |
| Outside pipe-Ø ASTM A312      | RA                | 13.72                         | 17.15 | 21.34 | 26.67 | 33.40 | -    | 42.16 | 48.26 | 60.33 |
| Wall thickness pipe ASTM A312 | a                 | dimensions acc. to S10 or S40 |       |       |       |       |      |       |       |       |
| Socket depth                  | b                 | 6                             | 10    | 10    | 13    | 13    | -    | 13    | 13    | 16    |
| Handwheel-Ø                   | B                 | 150                           | 150   | 150   | 150   | 150   | 150  | 150   | 150   | 150   |
| Wrench size across flats      | S <sub>1</sub>    | 10                            | 10    | 10    | 10    | 10    | 13   | 13    | 13    | 13    |
| Wrench size across flats      | S <sub>2</sub>    | 30                            | 30    | 30    | 30    | 30    | 36   | 36    | 36    | 36    |
| Weight                        | ca. kg            | 1.6                           | 1.85  | 1.9   | 2.3   | 2.7   | 3.6  | 5.1   | 5.1   | 7.7   |
| Kvs-Value                     | m <sup>3</sup> /h | 1.6                           | 2.8   | 4.3   | 6.7   | 11.5  | 14.0 | 20.6  | 22.6  | 37.1  |
| Cv-Value                      | gal/min           | 1.9                           | 3.3   | 5.0   | 7.8   | 13.4  | 16.2 | 26.3  | 26.3  | 43.2  |

Dimensions in mm.